

## QSFP+ 40G DAC Active 30AWG 1MQSFP+ 40G DAC Active Copper Cable

### QSFP-DAC-P1M-T

(For Cisco, HP, Aruba, Juniper, PaloAlto, Fortigate and others brand compatible)



### Features

- ◆ QSFP+ conforms to the Small Form Factor SFF8436
- ◆ 4-Channel Full-Duplex Active Copper Cable
- ◆ Support for multi-gigabit data rates :1GGb/s - 10Gb/s (per channel)
- ◆ Maximum aggregate data rate: 40Gb/s (4 x 10Gb/s)
- ◆ Copper link length up to 10m (active limiting)
- ◆ High-Density QSFP 38-PIN Connector
- ◆ Power Supply :+3.3V
- ◆ Low crosstalk
- ◆ I2C based two-wire serial interface for EEPROM signature which can be customized
- ◆ Temperature Range: 0~ 70 °C

### Overview

The QSFP+ cable assemblies are high performance, cost effective I/O solutions for LAN, HPC and SAN. The high speed cable assemblies meet and exceed Gigabit Ethernet, InfiniBand and Fiber Channel commercial temperature requirements for performance and reliability.

The cables are compliant with InfiniBand Architecture, SFF-8436 specifications and provide connectivity between devices using QSFP ports.

### Applications

- ◆ 10 Gigabit Ethernet
- ◆ 40 Gigabit Ethernet
- ◆ InfiniBand4x SDR, DDR, QDR
- ◆ 2, 4, 8, 10 Gigabit Fiber Channel
- ◆ Fiber Channel over Ethernet
- ◆ SAS, Servers, Hubs, Switches, Routers

### Ordering Information

Part Number	Product Description
QSFP-DAC-P1M-T	QSFP+ 40G Passive 0.5MQSFP+ 40G DAC 0.5M40GDAC0.5mQSFP+ to QSFP+0~70°C 30AWG
QSFP-DAC-P2M-T	QSFP+ 40G Passive 1MQSFP+ 40G DAC 1M40GDAC1mQSFP+ to QSFP+0~70°C 30AWG
QSFP-DAC-P3M-T	QSFP+ 40G Passive 1.5MQSFP+ 40G DAC 1.5M40GDAC1.5mQSFP+ to QSFP+0~70°C 30AWG
QSFP-DAC-P5M-T	QSFP+ 40G Passive 2MQSFP+ 40G DAC 2M40GDAC2mQSFP+ to QSFP+0~70°C 30AWG
QSFP-DAC-P7M-T	QSFP+ 40G Passive 3MQSFP+ 40G DAC 3M40GDAC3mQSFP+ to QSFP+0~70°C 30AWG
QSFP-DAC-P7M-T	QSFP+ 40G Passive 5MQSFP+ 40G DAC 5M40GDAC5mQSFP+ to QSFP+0~70°C 28AWG
QSFP-DAC-P10M-T	QSFP+ 40G Passive 7MQSFP+ 40G DAC 7M40GDAC7mQSFP+ to QSFP+0~70°C 26AWG

### Recommended Operating Conditions

Parameter	Symbol	Min	Typical	Max	Unit
Storage Ambient Temperature		-40		+85	°C
Operating Case Temperature	Tc	0		+70	°C
Power Supply Voltage	Vcc3	3.14	3.3	3.47	V
Power Dissipation	PD			2.5	W
Data Rate Per Lane		1		10	Gb/s

### Pin Descriptions

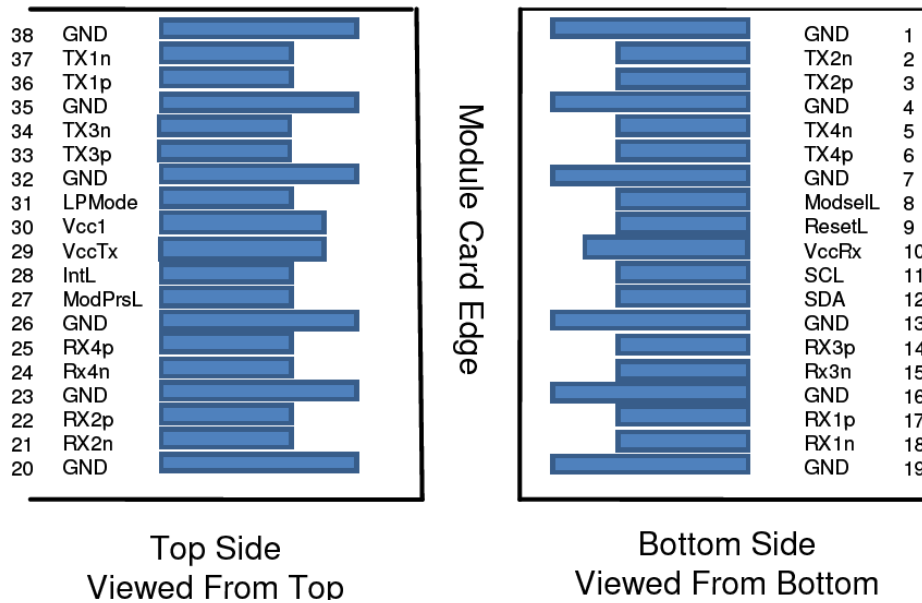

Figure1. Pin Descriptions

Pin	Logic	Symbol	Name/Description	Notes
1		GND	Ground	1
2	CML-I	Tx2n	Transmitter Inverted Data Input	
3	CML-I	Tx2p	Transmitter Non-Inverted Data Input	
4		GND	Ground	1
5	CML-I	Tx4n	Transmitter Inverted Data Input	
6	CML-I	Tx4p	Transmitter Non-Inverted Data Input	
7		GND	Ground	1
8	LVTTL-I	ModSelL	Module Select	
9	LVTTL-I	ResetL	Module Reset	

Datasheet

10		Vcc Rx	+3.3V Power Supply Receiver	2
11	LVCMSI/O	SCL	2-wire serial interface clock	
12	LVCMSI/O	SDA	2-wire serial interface data	
13		GND	Ground	1
14	CML-O	Rx3p	Receiver Non-Inverted Data Output	
15	CML-O	Rx3n	Receiver Inverted Data Output	
16		GND	Ground	1
17	CML-O	Rx1p	Receiver Non-Inverted Data Output	
18	CML-O	Rx1n	Receiver Inverted Data Output	
19		GND	Ground	1
20		GND	Ground	1
21	CML-O	Rx2n	Receiver Inverted Data Output	
22	CML-O	Rx2p	Receiver Non-Inverted Data Output	
23		GND	Ground	1
24	CML-O	Rx4n	Receiver Inverted Data Output	
25	CML-O	Rx4p	Receiver Non-Inverted Data Output	
26		GND	Ground	1
27	LVTTL-O	ModPrsL	Module Present	
28	LVTTL-O	IntL	Interrupt	
29		Vcc Tx	+3.3V Power supply transmitter	2
30		Vcc1	+3.3V Power supply	2
31	LVTTL-I	LPMODE	Low Power Mode	
32		GND	Ground	1
33	CML-I	Tx3p	Transmitter Non-Inverted Data Input	
34	CML-I	Tx3n	Transmitter Inverted Data Input	
35		GND	Ground	1
36	CML-I	Tx1p	Transmitter Non-Inverted Data Input	
37	CML-I	Tx1n	Transmitter Inverted Data Input	
38		GND	Ground	1

**Note:**

1. GND is the symbol for signal and supply (power) common for the QSFP+ module. All are common within the QSFP+ module and all module voltages are referenced to this potential unless otherwise noted. Connect these directly to the host board signal-common ground plane.
2. Vcc Rx, Vcc1 and Vcc Tx are the receiver and transmitter power supplies and shall be applied concurrently. Requirements defined for the host side of the Host Edge Card Connector are listed in Table 6. Recommended host board power supply filtering is shown in Figure 4. Vcc Rx Vcc1 and Vcc Tx may be internally connected within the QSFP+ Module in any combination. The connector pins are each rated for a maximum current of 500 mA.

## Mechanical Dimensions

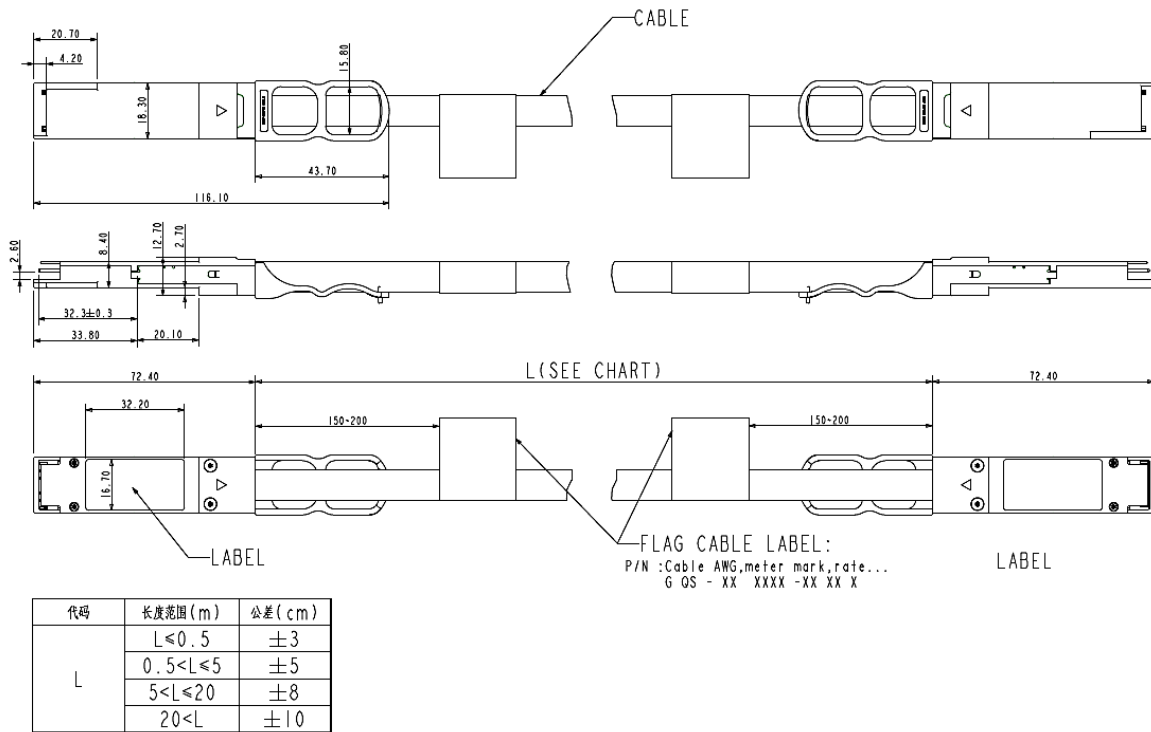

Figure2. Mechanical Specifications

## References

1. QSFP+ conforms to the Small Form Factor SFF-8436
2. Support for multi-gigabit data rates :1 Gb/s - 10 Gb/s (per channel)

### ITK Connecting Co.,Ltd.

ITK Connecting reserves the right to make changes to or discontinue any optical link product or service identified in this document without notice in order to improve design and/or performance. If you have any question regarding this specification sheet, please contact our sales representative or send email to [sales@itk.co.th](mailto:sales@itk.co.th)